

SECTION A-A

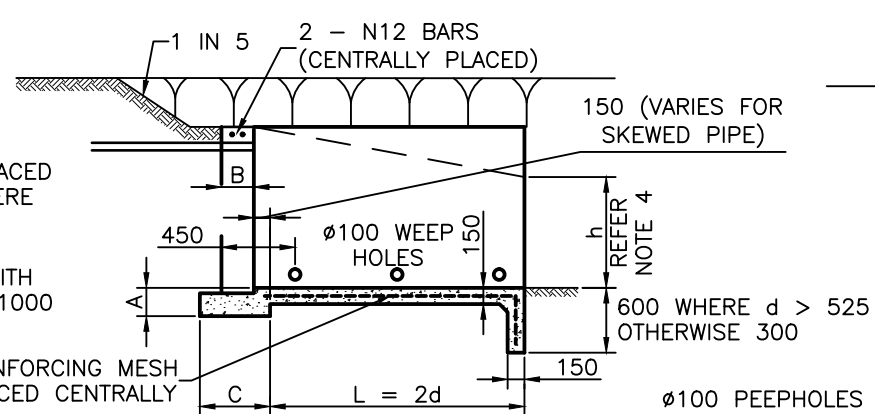

SECTION B-B

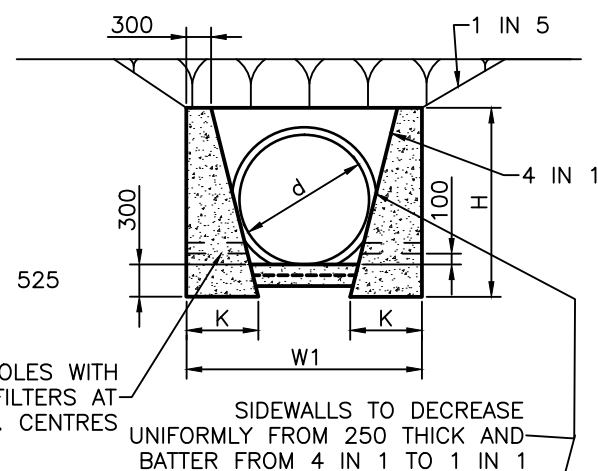

SECTION C-C

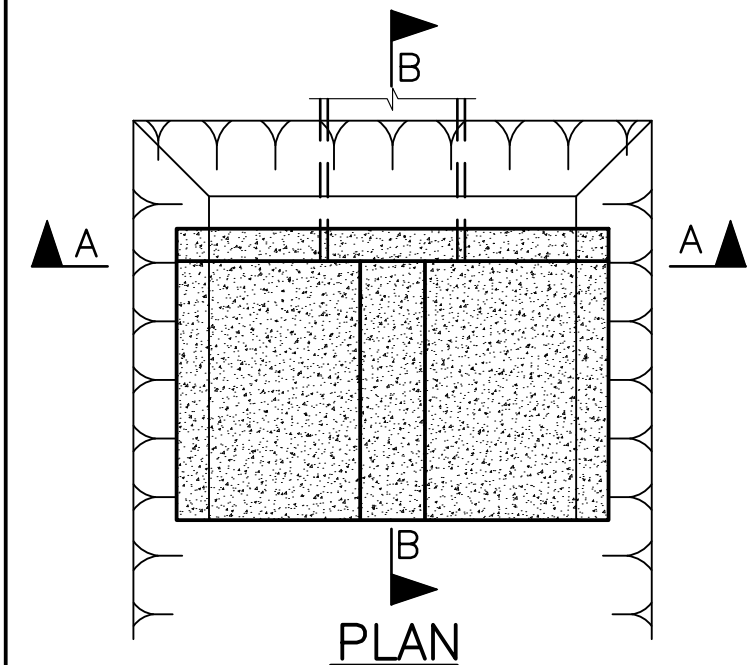

PLAN

PIPE SKEW	5°-15°	16°-25°	26°-35°	36°-45°
SKEW FACTOR	1.02	1.07	1.16	1.32

- * FOR SKEWED PIPES - MULTIPLY W1 AND W2 BY SKEW FACTOR.
- * FOR MULTIPLE PIPES INCREASE W1 AND W2 BY DIMENSION 'X' FOR EACH ADDITIONAL PIPE. ('X' BEING THE DISTANCE FROM PIPE ϕ TO PIPE ϕ).

MULTIPLE SKEW PIPES

TYPE A OR TYPE B

DIMENSION	PIPE DIAMETER 'd'															
	300	375	450	525	600	675	750	825	900	1050	1200	1350	1500	1650	1800	1950
A	150	150	150	200	200	200	250	250	250	250	250	300	300	300	300	300
B	225	225	225	300	300	300	300	300	300	300	300	300	300	300	300	300
C	450	450	450	450	450	450	600	600	600	600	600	600	600	600	600	600
H	580	670	750	830	900	980	1060	1140	1220	1370	1530	1690	1840	2000	2160	2340
T	150	150	150	200	200	200	200	200	200	200	200	200	200	200	200	200
W1*	700	730	760	790	820	850	880	920	950	1010	1070	1140	1200	1260	1320	1380
W2*	1860	2070	2260	2450	2620	2810	3000	3200	3390	3750	4130	4520	4880	5260	5640	6060
'X'	510	595	685	765	850	935	1015	1095	1180	1345	1510	1675	1835	2000	2165	2340

DIMENSIONS

TYPE A INLET FOR d = 300 TO 1200

TYPE A OUTLET FOR d = 300 TO 1950

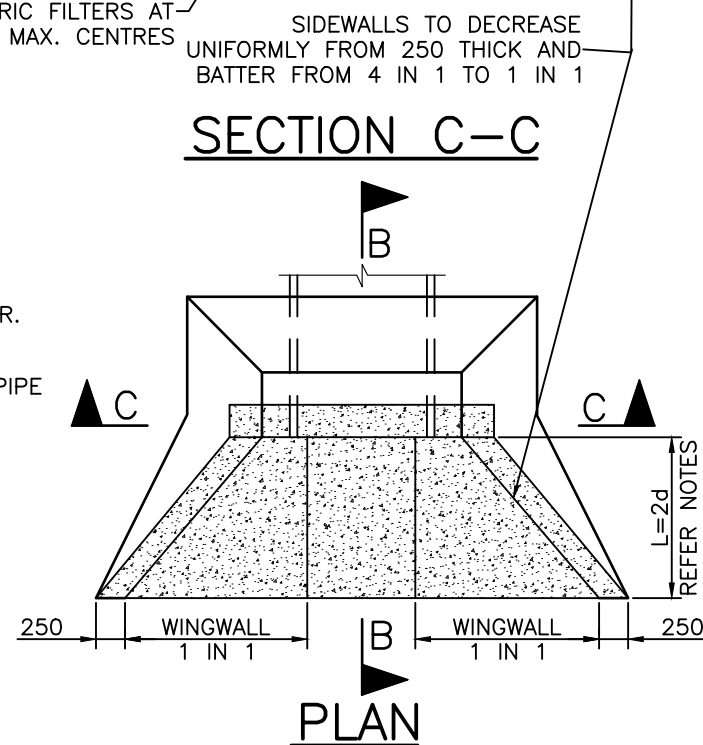

PLAN

DIMENSION	PIPE DIAMETER 'd'				
	1350	1500	1650	1800	1950
A	300	300	300	300	300
B	300	300	300	300	300
C	600	600	600	600	600
K	800	840	875	915	960
H	2000	2160	2300	2460	2640
W1*	2500	2700	2890	3085	3135
'X'	1675	1835	2000	2165	2340

DIMENSIONS

TYPE 'B' INLET AND OUTLET

FOR d = 1350 to 1950

NOTES:

- DESIGN ALLOWABLE BEARING PRESSURE 75 kPa. WHERE THIS BEARING PRESSURE CANNOT BE OBTAINED, THE SUPERINTENDENT MAY DIRECT THAT A WIDER FOOTING BE USED.
- UNREINFORCED CONCRETE CLASS 20 MPa/20. REINFORCED CONCRETE CLASS 32 MPa/20. CONCRETE COVER TO 50 UNLESS SHOWN OTHERWISE.
- IN TIDAL AREAS WHERE MESH REINFORCEMENT IS SPECIFIED, CONCRETE IS TO BE SULPHATE RESISTANT GRADE S40.
- IN EMBANKMENT SITUATIONS, THE HEIGHT OF THE WING WALL AT THE TOE SHOULD BE REDUCED TO "h" SO THAT THE SLOPE OF THE TOP OF THE WING WALL EQUALS THE ADJACENT EMBANKMENT BATTER. (REFER TO PROJECT DRAWINGS FOR VALUE OF "h").
- SEE PROJECT DRAWINGS FOR THE FOLLOWING: NUMBER AND DIAMETER OF PIPES; SKEW ANGLES OF PIPES, IF APPLICABLE; INVERT LEVELS OF PIPES; HEIGHT OF WING WALL "h" AT TOE IF APPLICABLE.
- FOR QUANTITIES REFER UMS 371.
- SCOUR PROTECTION IS GENERALLY REQUIRED DOWNSTREAM OF THE APRON UNDER ANY ONE OF THE FOLLOWING CONDITIONS:
 - AVERAGE OUTLET VELOCITY EXCEEDS THE NON-EROSIVE VELOCITY.
 - AVERAGE OUTLET VELOCITY EXCEEDS 2m/s.
 - OUTLET JET IS EXPECTED TO STRIKE AN UNPROTECTED CHANNEL BANK WITHIN A DISTANCE OF 10 TIMES THE PIPE DIAMETER.
- BED SCOUR MAY BE CONTROLLED BY THE FOLLOWING METHODS:
 - REDUCING THE OUTLET VELOCITY BY INSTALLING AN EXPANSION CHAMBER.
 - INSTALLING AN ENERGY DISSIPATER.
 - ARMOURING THE BED WITH ROCK, USUALLY OVER A MAXIMUM DISTANCE OF 8 TIMES THE PIPE DIAMETER.
- PREFERRED POSITIONING OF STORMWATER PIPE OUTLET:
 - SETBACK FOR MORE THAN A DISTANCE OF 3 TIMES THE BANK HEIGHT MEASURED FROM THE TOE OF THE WATERCOURSE BANK.
 - FOR 'NARROW' RECEIVING WATERCOURSE, ANGLE THE OUTLET PIPE IN THE DIRECTION OF THE MAIN FLOW. AN APPROACH ANGLE IN THE RANGE OF 45° TO 60° MEASURED FROM THE BANK IS RECOMMENDED.
 - LIMIT THE MAXIMUM HEIGHT BETWEEN THE OUTLET INVERT AND THE RECEIVING CHANNEL INVERT OR EXPECTED WATER LEVEL TO $0.247/d^{0.5}$ WHERE d IS THE OUTLET PIPE DIAMETER IN METRES.
- WHERE DIRECTED, INSTALL 1200 HIGH FENCE ALONG HEADWALL AND WINGWALLS:
 - FOR 1000-1500 DROP HEIGHT, PROVIDE GALVANISED TUBULAR HANDRAIL IN ACCORDANCE WITH UMS 241, GALVANISED WELD MESH FENCING IN ACCORDANCE WITH UMS 242 OR PEDESTRIAN SAFETY FENCING IN ACCORDANCE WITH UMS 243.
 - FOR >1500 DROP HEIGHT, PROVIDE POWDER COATED STEEL FENCING (HUNTER ROD TOP OR APPROVED EQUIVALENT) INSTALLED USING VANDAL PROOF FIXINGS. DESIGN TO RESIST A MINIMUM STATIC LOAD OF 1.5 kN/m AS PER CLAUSE 3.6 OF AS 1170-2002.
- USE OF EQUIVALENT PRECAST PRODUCTS IS PERMITTED.
- DIMENSIONS IN MILLIMETRES (U.N.O.).

ISSUE	AMENDMENT	DRAWN DATE	CHK'D DATE	APPR'D DATE
C	Reo Designation Updated on Sections A-A & B-B	DJL 11/10	IC 12/10	PC 01/11
B	Notes 10 Modified.	DJL 07/07	BH 08/07	BH 08/07
A	ORIGINAL ISSUE	April '01	May '01	June '01

DESIGN AUTHORIZED FOR ISSUE B. BALL SIGNATURE ON ORIGINAL DATED 29/6/01	DESIGN	STD DWG GROUP	DATE	April '01
MANAGER ASSET SUPPORT - R.P.E.Q: 3 8 5 2	DRAWN	CITY DESIGN	DATE	April '01
DESIGN APPROVED	CHECKED	M. STEER	DATE	May '01
B. HANSEN SIGNATURE ON ORIGINAL DATED 27/6/01	DRAWING FILENAME	UMS 341		
PRINCIPAL ASSET OFFICER ROADS & DRAINAGE	ASSOCIATED PLANS	SUPERSEDES WS 53-1		



BRISBANE CITY COUNCIL STANDARD DRAWING

INLETS AND OUTLETS (CONCRETE) STORMWATER DRAINS

SCALE	NOT TO SCALE
DWG No.	UMS 341
ORIGINAL SIZE	A3
REVISION	C